

Installation and Operating Instructions

All models 5 and 8 function,
stainless steel and white:



For your convenience, we recommend to attach the serial number label HERE.

As part of Parmco Appliances commitment to improving and updating product ranges, we reserve the right to alter, change and update technical specifications and appearance attributes of all Parmco Appliances products. E&OE.



Dear Valued Customer,

Thank you and congratulations on purchasing your new Parmco appliance.

All Parmco products are made to the highest quality and design standards. We are sure you will enjoy your new appliance.

As a note, please read through these instructions carefully, as these will assist you in gaining a complete understanding of the functions and features offered by your appliance.

Please take special note of all detailed technical information and installation instructions. It is essential that you only allow a qualified technician to install this appliance to ensure the safety and reliability of this appliance.

Furthermore, not using appropriate personnel to install this appliance may affect any future warranty claims lodged, so please check with Parmco Appliances before any installation is carried out.

We hope you enjoy your new appliance. If you would like to find out more about this product or any other products in Parmco's extensive range, visit us on the web at www.parmco.co.nz.

Regards,
The Parmco Team



INDEX

Important Safety Information	PAGE
Before Using this Appliance	4
For your Safety	4
Use and Care	
Description of the appliance	5
Positioning of the oven Trays & Shelves	7
Cooking Modes	8
Electronic Timer	10
Cooking guide	14
Maintenance	16
Installation Instructions	
Notes to the Installer	18



IMPORTANT NOTE

It is the law in New Zealand that this appliance must be installed by authorised persons. The installation must comply with all the appropriate New Zealand Standards and Regulatory Requirements with particular reference to the New Zealand Electrical Standards.

Any attempt to install this or any other Parmco product without an authorised person could result in damage to the product and a possible health hazard. Not having an authorised person install this appliance may result in all associated warranties from Parmco Appliances being null and void.

IMPORTANT SAFETY INFORMATION

We recommend that for best performance and to extend the life of your appliance you read the instructions in this owner's manual thoroughly before using your new appliance. It will provide you with all the information you need to ensure its safe installation, proper use and maintenance. Retain this owner's manual for future reference.

To maintain the efficiency, and safety of this appliance we recommend the following:

BEFORE USING THIS APPLIANCE

Read the instructions thoroughly

- Remove all plastic protective films on the appliance before operating the appliance.
- Remove the plastic film on the oven glass door (when provided).
- To condition the oven for its first use, it is necessary to allow oils and residues used to protect the appliances during manufacturing to burn off. Heat the empty oven at maximum temperature for 45 minutes. This allows unpleasant smells and smoke from protective oils used during manufacture and from new thermal insulation to burn off.
- Allow the unit to cool off and wash the oven out with soapy water and then rinse.

FOR YOUR SAFETY

- This appliance is designed for non-commercial, household use only and must not be altered in any way.
- This appliance can only be used safely when it is correctly connected to an efficient earthing system in compliance with New Zealand Electrical Standards requirements.
- Before maintenance or cleaning, always ensure that the appliance is disconnected from the mains.
- Always use oven gloves to remove and replace cookware in the oven.
- Packaging items such as plastic bags, polystyrene, nails, etc that this appliance is delivered in are potentially dangerous, and therefore appropriate measures must be taken to prevent children from coming into contact with them.
- This appliance must only be used by adults. Make sure that children do not touch the controls or play with the appliance. Young children should be supervised to ensure they do not play with the appliance.
- Do not allow children to sit on or play with the oven door.
- Do not use the drop down door as a stool to reach overhead cabinets.
- This appliance is not intended for use by persons (including children) with reduced physical, sensory, mental capabilities, or lack of experience and knowledge, unless they have been given supervision or instruction concerning the use of this appliance by a person responsible for their safety.
- During use the appliance becomes hot. Care should be taken to avoid touching heating elements inside the oven.
- Keep the appliance thoroughly cleaned. Food residues may cause fire risks.
- DO NOT use a steam cleaner to clean this appliance.

- NEVER line the oven with aluminium sheets as doing so may damage the enamel and elements.
- WARNING: Accessible parts may become hot during use. To avoid burns young children should be kept away.
- Do not use harsh abrasive cleaners or sharp metal scrapers to clean the oven door glass since they can scratch the surface, which may result in shattering of the glass.
- After using the appliance, please ensure that all controls are in the “OFF” position.
- Avoid touching the oven with wet body parts.
- Avoid improper or dangerous use of this appliance.
- Do not obstruct the ventilation or heat dissipation slots.
- Do not allow power cables of other appliances to come into contact with hot parts of this appliance.
- This appliance is intended for indoor use only. Avoid exposing the appliance to atmospheric elements such as direct sunlight and rain.
- DO NOT USE OR STORE FLAMMABLE MATERIALS IN THE APPLIANCE OR NEAR IT.
- For any enquiries please contact Parmco Appliances (09) 573 5678.



USE AND CARE OF APPLIANCE

This multi-function oven combines the advantages of traditional convection ovens with a modern fan assisted oven in a single appliance. It is an extremely versatile appliance that allows you to choose easily and safely between different cooking modes. The various cooking modes are selected by means of the cooking mode selection knob located on the control panel.

Oven performance

It is important to remember that this oven may perform differently to the way your previous appliance worked. To obtain the best cooking results, please experiment with temperature, rack height and cooking times. As a helpful guide to help you with this process please refer to the “Cooking Mode Table”.

Steam and Condensation

Often owners of new ovens will see a higher level of steam and condensation than they are used to in their previous appliance. This is normal and contributes to keeping the food moist during cooking. The amount of condensation will depend on the type of food (fresh, defrosted, frozen) being cooked and the cooking style (water in the roasting dish). Climatic conditions also contribute to the generation of condensation.

When food is heated it produces steam in the same way a boiling kettle does. When steam comes into contact with the oven door glass it will condensate and produce droplets. To reduce condensation, ensure that the oven is well heated before placing food in the oven cavity. **Oven pre-heating is necessary before any cooking!**

It is normal for steam to escape the oven when opening the door. To reduce the build up of condensation pre heat the oven for longer periods and occasionally open the door and carefully wipe away the condensation. Adjusting your cooking practices will also ensure a minimum build up of condensation.

Controls

- Electronic Programmers (8 Function Models)

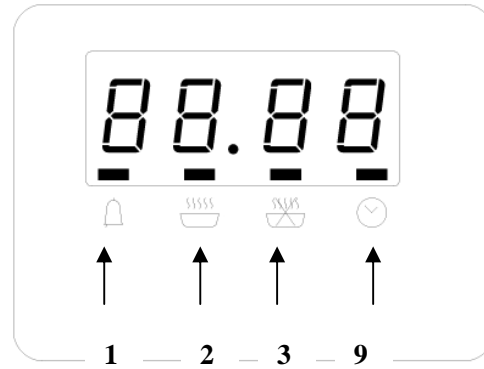
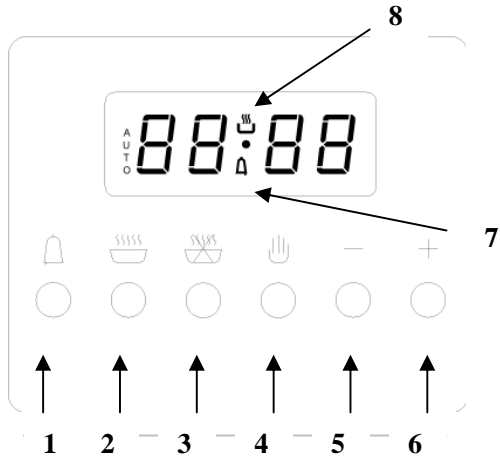

1. Timer
3. End cooking time selector
5. Adjust backwards selector
7. Timer indicator
9. Clock selection indicator

2. Cooking time selector
4. Manual operation selector
6. Adjust forward selector
8. Cooking indicator

Description of Appliance

- Control panel
- Cooking mode selection knob
- Cooking temperature selection knob
- Electronic programmer.
- Oven indication light (certain models only)
- Dripping pan or baking sheet
- Oven wire rack
- Easy clean side racks

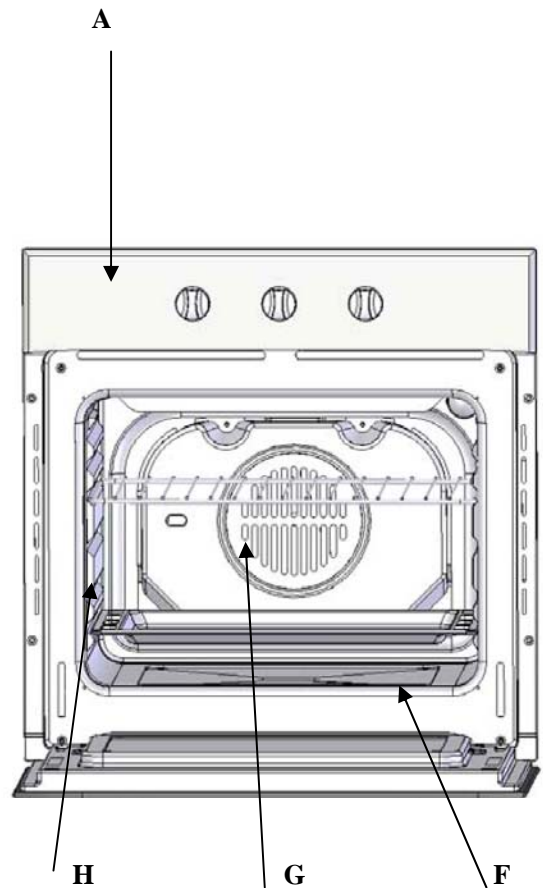
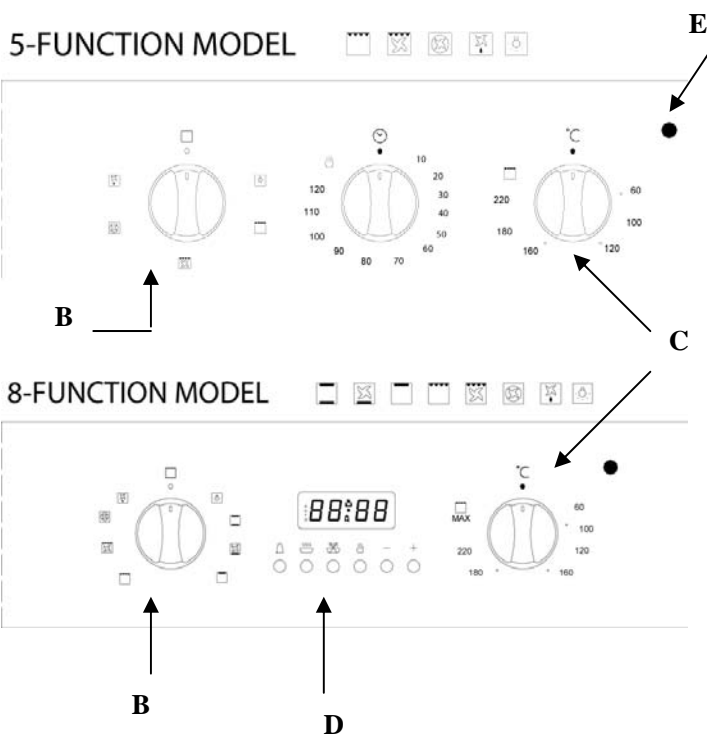

5 and 8 PUSH BUTTON MODEL

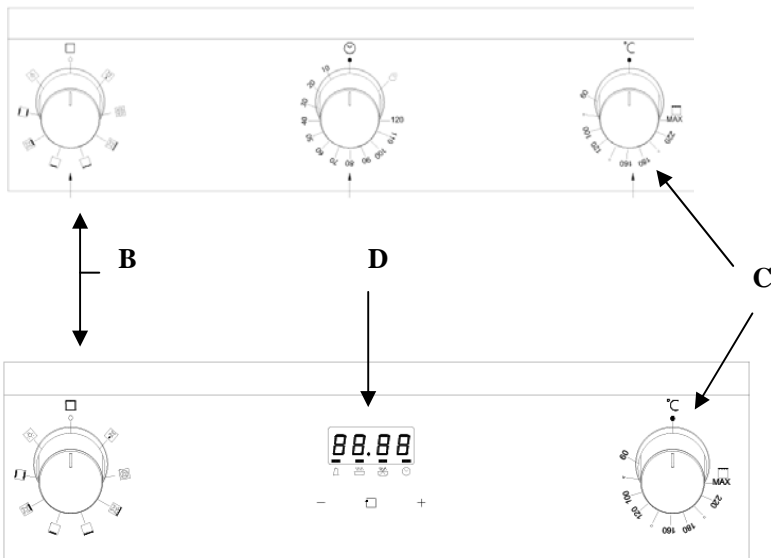

Positioning the Oven Trays & Shelves

The baking tray, grill tray and wire shelves can be located in any of five height positions. When positioning tray heights, it is important to remember that this oven may perform differently to the way your previous appliance worked. To obtain the best cooking results please experiment with temperature, rack height and cooking times. As a helpful guide to help you with this process, please refer to the "Cooking Mode Table". When fitting the wire racks or trays please ensure that they are located between the two wires that are closest together on the side racks. Wire racks have a safety stop so that they cannot be fully withdrawn by accident. To fully withdraw the wire racks simply lift the front edge slightly and withdraw the rack from the oven. The baking tray does not have a stop position and can be fully withdrawn from the oven without interruption.

BE CAREFUL NOT TO ACCIDENTALLY FULLY WITHDRAW THE TRAY.

Fit the trays and shelves between the two closest wires as shown right

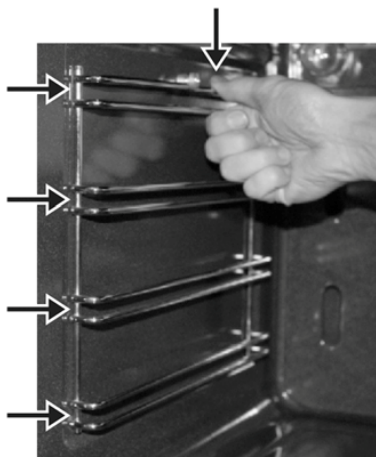

To remove the side support racks, push down on the wire below the locking pin, pull away from the oven wall until you can release the bottom of the support from the holes in the oven wall. To replace, reverse this procedure.

To operate this oven:

- NOTE: THE OVEN CLOCK MUST BE SET IN ORDER FOR THE OVEN TO OPERATE.
- Ensure that manual mode is selected (Page 8).
- Turn the cooking mode selection knob to the desired cooking mode (explanation of cooking modes is on pages 8 to 9).
- Turn the temperature selection knob to the desired temperature (please refer to the helpful cooking guide).
- If grilling, turn the temperature selection knob to “MAX”.

The first time you use your appliance, we recommend that you set the temperature to “MAX”, set the cooking mode selection knob to a cooking mode, and leave the oven operating empty for approx 45 minutes. Then turn off the appliance and allow it to cool. Any odours that may be detected during this initial use are due to the evaporation of substances used to protect the appliance during manufacture and storage.

NOTE: Place the baking tray provided on the bottom shelf position to prevent any spillages from dripping onto the bottom of the oven. **Never place anything (including foil and oven trays) directly onto the bottom of this oven when it is in operation as this could damage the enamel.** Only place your cookware (dishes, trays, aluminium foil etc) on the oven shelves provided with this appliance.

COOKING MODES

Please note the model you have purchased may not have all of the functions described below.

NOTE: To use your oven in manual mode (not using the end time cooking programmer), the  symbol must be selected on the control knob.

Convection Mode 

When set to Convection Mode, the top and bottom heating elements operate together like a ‘normal’ conventional oven that you have probably used before.

Convection mode is best suited for traditional baking and roasting and you should only use one shelf at a time, otherwise there will be uneven heat distribution. You can balance the amount of heat between the top and bottom of the dish by selecting a different shelf height. If you want more heat at the top of the dish, place the dish on the top or second shelf. For more heat on the bottom of the dish place the dish on the third or fourth shelf.

Delicate Cooking Mode



When set to Delicate Cooking Mode, the bottom element and the fan will operate. This mode is most suitable for pastries, cakes and non-dry sweets in baking tins or moulds that require heat from the bottom.

Top Heat Mode



When set to Top Heat Mode, the top heating element operates. This mode can be used to brown food at the end of cooking.

Grill Mode



When Grill Mode is selected the top inner element operates. Set the temperature to “MAX” when using grill function. The extremely high and direct temperature of the grill makes it possible to brown the surface of meats and roasts while locking in the juices to keep them tender. Grill mode can also be used for dishes that require a high temperature on the surface of the dish such as steak, ribs, fillets, hamburgers etc. Grill the food with the oven door closed to avoid high temperatures on control knobs and surfaces.

Fan Assisted Grill Mode



When the Fan Assisted Grill Mode is selected the inner element and fan operate. This mode increases the circulation of the heated air throughout the oven, which helps prevent food from burning on the surface and allowing the heat to fully penetrate the dish. This mode is particularly useful for kebabs made with meats and vegetables, sausages, ribs, chops chicken etc. In fan assisted grill mode, grill with the door closed to avoid high surface temperatures on control knobs and surfaces. When using fan assisted grill mode, place the food on the 2nd or 3rd oven shelf from the bottom. Place a dripping pan on the first rack to prevent grease and fats from dripping onto the oven floor.

We recommend using 200°C with this mode as it is the most efficient temperature. However this does not mean you cannot use lower temperatures if you desire to use a different temperature.

Baking Mode (Fan Forced)



When Baking Mode is selected, the fan element and fan operate to provide a delicate heat that is more evenly distributed throughout the oven.

This mode is ideal for baking and cooking delicate foods on multiple shelves, especially cakes that need to rise such as cream puffs, biscuits, swiss rolls etc.

NOTE: This function relies on the air circulation within the oven cavity to provide even temperatures and as such the size and placement of trays can affect the temperature distribution. It is usual to have some temperature variations within the oven cavity and this function is NOT a guarantee of perfectly even temperatures throughout the oven.

Defrost Mode 

When Defrost Mode is selected, the fan located at the back of the oven circulates room temperature air around the oven. This is recommended for defrosting all types of food but is particularly effective at defrosting delicate food items. It is possible to accelerate the defrosting process by selecting multi-cooking mode and setting the temperature between 80°C and 100°C.

End Cooking knob (I) (only available on certain models)

These models are equipped with a timer to control when the oven shuts off during cooking. Position the timer knob (I) between 10 minutes and 120 minutes as required. At the end of the selected time period the timer will sound and the oven will turn off.

ELECTRONIC TIMER

NOTE: The clock must be set in order for the oven to operate.

6 BUTTON DIGITAL CLOCK (only available on certain models)

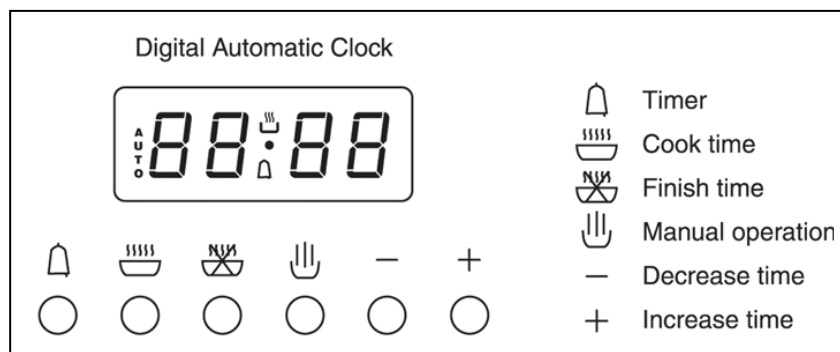

This appliance has a digital display 24 hour clock with six control buttons. When the power is connected, the screen displays 3 flashing numbers and “AUTO”.

Adjusting the Digital Clock



To set the correct time, press the  button first and then the + or – button to increase or decrease until the correct time is displayed.

Manual Operation Setting

If **"AUTO"** is flashing, automatic or semi automatic program has been set. Press the  button. **"AUTO"** will clear from the display and the oven can be operated manually.



Automatic Setting



Automatic setting of the oven allows you to select the end time, cooking time, temperature and cooking mode. The oven will switch on, cook according to the selected cooking mode and temperature, then switch off automatically.

1. Press  button, set the cooking time with the + and – buttons.
2. Press  button, set cooking finish time with + and – buttons.
3. Set cooking temperature and cooking mode by turning the thermostat knob and mode selector knob.

After the above setting, **"AUTO"** will illuminate, which means the automatic cooking feature of the oven is set.

For Example: If cooking time takes 45 minutes and you want it to finish at 14:00:



1. Press  button, set the cooking time to 45 minutes with the + and – buttons.
2. Press  button, set finish time to 14:00 with + and – buttons.
3. Set cooking temperature and cooking mode by turning the thermostat knob and mode selector knob.

After the above setting, the current time is displayed and **"AUTO"** will flash, indicating that the automatic cooking feature is set. When the clock displays 13:15, the oven will start cooking automatically. While cooking, **"AUTO"** and  will flash. When the clock displays 14:00, the oven automatically stops cooking. The alarm will ring and **"AUTO"** will flash. Press the  button and the ringing will stop.

Semi Automatic Setting

1. Press  button, set cooking finish time with + and – buttons. (Up to 23 hours and 59 minutes).
2. Set cooking temperature and cooking mode by turning the thermostat knob and mode selector knob.

The oven starts immediately  and **"AUTO"** will flash. At the finish time reached, the oven automatically stops cooking. The alarm will ring and **"AUTO"** will flash. Press the alarm bell to stop the ringing.

When the  button is pressed during semi-automatic cooking, the set cooking time is displayed. If the  button is pressed and the time set back to 0, the semi-automatic setting will be cancelled. When the  button is pressed again, the oven will revert back to manual mode.

Timer

The digital timer can be set up to 23 hours and 59 minutes maximum. To set the timer, press alarm button  button and then + or – button until the desired time is displayed. Once the alarm button is released, the current time and alarm symbol will be displayed. When the alarm button is pressed, the remaining time is displayed. When the set time is reached, the alarm symbol disappears and the alarm will ring. To stop the alarm, press the alarm button.

NOTE: After pressing the alarm button, timer settings should be entered within 5 seconds. In case of power failure, all settings including the time display will be lost. When the power is restored, three '0' and **"AUTO"** will be displayed.

3 BUTTON DIGITAL CLOCK (only available on certain models)

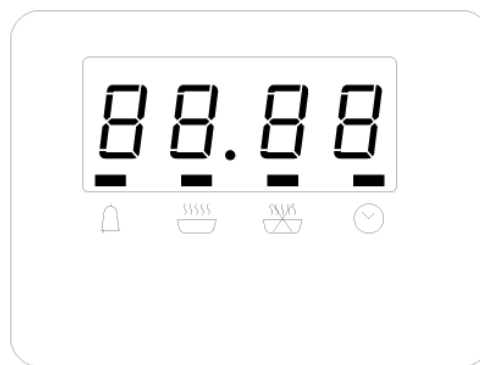





Adjusting the Clock

Once the oven has been connected to the electrical power, the display will show "12:00" with a square bar highlighted above the  symbol. Press the + or – button to increase or decrease the number until it reaches the correct time. After 5 seconds the clock is set and will start automatically.



Automatic Setting



Automatic setting of the oven allows you to select the end time, cooking time, temperature and cooking mode. The oven will switch on, cook according to the selected cooking mode and temperature and then switch off automatically.

1. Press the function button repeatedly until the highlighted bar above the  symbol flashes. Set the cooking time with the + and – buttons.
2. Press the function button repeatedly until the highlighted bar above the  symbol flashes. Set cooking finish time with + and – buttons.
3. Select the cooking function and temperature with the control knobs. The symbols above  and  will flash indicating the cooking procedure has been set.

After the above setting, “**AUTO**” will illuminate, which means the automatic cooking feature of the oven is set.

For Example: If cooking time takes 45 minutes and you want it to finish at 14:00:



1. Press  button, set the cooking time to 45 minutes with the + and – buttons.
2. Press  button, set finish time to 14:00 with + and – buttons.
3. Set cooking temperature and cooking mode by turning the thermostat knob and mode selector knob.

After the above setting, the current time is displayed and “**AUTO**” will flash, indicating that the automatic cooking feature is set. When the clock displays 13:15, the oven will start cooking automatically. While cooking, “**AUTO**” and  will flash. When the clock displays 14:00, the oven automatically stops cooking. The alarm will ring and “**AUTO**” will flash. Press  button and the ringing will stop.

Start Cooking Now and set the Finish Time



1. Press  button, set cooking finish time with + and – buttons. (Up to 23 hours and 59 minutes).
2. Set cooking temperature and cooking mode by turning the thermostat knob and mode selector knob.

The oven starts immediately,  and “**AUTO**” will flash. When the finish time is reached, the oven automatically stops cooking. The alarm will ring and “**AUTO**” will flash. Press the alarm bell to stop the ringing.

When the  button is pressed during semi-automatic cooking, the set cooking time is displayed. If the  button is pressed and the time set back to 0, the semi-automatic setting will be cancelled. When the  button is pressed again, the oven will revert back to manual mode.

Timer

The digital timer can be set up to 23 hours and 59 minutes maximum.

To set the timer, press the function button repeatedly until the square bar above the  symbol flashes, and adjust the time by pressing the + or – buttons. The timer countdown will begin to work. When it reaches the set time, the square bar above the  symbol begins to flash and the alarm will ring. To stop the alarm ringing, press any button.

NOTE: when making time and mode selections they must be entered within 5 seconds. In case of power failure, all settings including the time display will be lost. When the power is restored, three '0' and "AUTO" will be displayed.

The Oven Light

Set the cooking mode selection knob to  to switch on the oven light/s. The oven light/s will stay on while the oven is operating.

Cooling / Ventilation



In order to keep the exterior of the appliance cool, the appliance is fitted with a cooling fan that operates automatically. When the oven is on, the cooling fan turns on and you will notice a flow of air exiting between the door and control panel.

NOTE: When cooking is finished, the cooling fan will continue operating until the oven has cooled down. The cooling fan will then turn off automatically.

Practical Cooking Advice

The oven offers a wide range of settings which allow you to cook any type of food in the best possible way. With time and experimentation you will learn the heat settings, cooking mode and shelf height that will deliver you the results that best match your cooking style. The advice given below is a guideline only which may be varied according to your own personal experience.





Pre-Heating of Oven

If the oven needs to be preheated, the convection mode  or  baking mode should be selected. These are the most efficient modes, which will reach the desired temperature as quickly as possible using the least amount of energy. Once the oven has been pre heated and the cooking mode selected, the food should be placed in the oven.

Multi-Shelf Cooking

If you want to cook food on several shelves, select the "Baking (Fan Forced)" mode  This is the only mode that allows you to cook on multi-shelves at the same time. When cooking delicate foods on more than one shelf, use "Baking Mode", as this allows you to cook on three shelves.

COOKING GUIDE

Selector knob setting	Food Type	Weight (in KG)	Rack height From bottom	PreHeat Time (mins)	Temp Deg C	Cook Time (mins)
Traditional Cooking 	Duck	1	3	15	200	65-75
	Roast Beef	1	3	15	200	70-75
	Roast Pork	1	3	15	200	70-80
	Roast Lamb	1	3	15	200	70-80
	Biscuits		3	15	180	15-20
	Tarts		3	15	180	30-35
Browning 			3/4	15	220	
Grill 	Fish	1	4	5	MAX	8-10
	Kebabs	1	4	5	MAX	6-8
	Vegetables	1	3/4	5	MAX	10-15
	Veal	1	4	5	MAX	15-20
	Cutlets	1	4	5	MAX	15-20
	Hamburgers	1	4	5	MAX	7-10
	Toasted sandwiches		4	4	MAX	2-3
Fan Assisted Grill 	Chicken	1.5	3	5	MAX	55-60
Baking 	Tarts	0.5	3	15	180	20-30
	Fruit cakes	1	2/3	15	180	40-45
	Sponge cake	0.5	3	15	160	25-30
	Small cakes On 2 racks	0.6	2-4	15	190	20-25
	Biscuits on 3 racks	0.7	1-3-5	15	180	20-25
	Meringues on 3 racks	0.5	1-3-5	15	90	180

Please note the above is a guide only and you will need to vary temperatures, times and rack height combinations to achieve the results you want.

MAINTENANCE

Cleaning the oven:

Before cleaning your appliance or performing maintenance, make sure that the cooking mode selection knob and cooking temperature selection knob is set to the “OFF” position. To extend the life of your oven, it must be cleaned frequently.

The inside of the oven should be cleaned soon after use when the oven is still warm (not hot) with warm soapy water. The soapy water should be rinsed away and the interior dried thoroughly. Avoid using abrasive detergents, scourers, acidic cleaners etc, as these may damage the enamel. If stains are particularly tough to remove, use cleaners specifically recommended to clean ovens and follow the instructions provided. **Never use a steam cleaner to clean the inside of this oven.**

If you are using the oven for an extended period of time, or if you are cooking dishes that contain a lot of water, condensation may form on the oven door. Dry it using a soft cloth and try reducing the cooking temperature.

There is a rubber seal surrounding the oven. Check the condition of the seal on a regular basis. If necessary, clean it but avoid using abrasive products or objects to do so. Should it become damaged please contact Parmco Appliances service department. We recommend you avoid using the oven until it has been repaired.



Never place anything (including foil and oven trays) on the bottom of the oven when it is in operation as this may result in damage to the enamel.

Clean the glass door using non-abrasive products or sponges and dry it with a soft cloth. Do not use abrasive cleaners or sharp scrapers to clean the oven door glass since they can scratch the surface and may result in shattering of the glass.

How to remove the oven door

You can remove the oven door for better access to the oven when cleaning.

- Open the door fully.
- Locate the hinge assembly (1).
- Lift the hinge tab to the open position (2).
- Gently close the door until the hinge assembly is against the door (3).
- Lift the door up and out at the same time.
- To replace the door reverse the above procedure, making sure that the hinge is correctly located on the small rebate in the hinge arm (4).

1

2

3





Replacing the Oven Lamps



WARNING: Ensure that the appliance is turned off before replacing the oven lamp/s to avoid the possibility of electric shock.

Remove the glass cover of the lamp-holder as shown below.

Remove the lamp and replace with a lamp resistant to high temperatures (300°C) with the following characteristics.

- Voltage 220 - 240V
- Wattage: 25W
- Type: E14

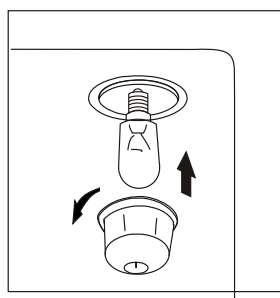

Replacement lamps are available from Parmco Appliances

Disposal

Parmco has a commitment to being environmentally responsible. To avoid potential negative impacts on the environment, please ensure that this appliance is disposed of correctly. This product must not be treated as household waste. Instead it should be handed over to an appropriate collection point for recycling of electrical, electronic and steel components. Disposal should always be carried out in an environmentally appropriate manner. For more detailed information about treatment, recovery and recycling of this product, please contact your local City Council office.

Service and Parts

Before leaving the factory, this appliance was tested and adjusted by specialist skilled staff to give the best operating results. Any subsequent necessary repairs or adjustments must be carried out with the greatest of care and attention by authorised personnel. For this reason, we strongly advise you to contact Parmco Service Department, specifying the nature of the problem, the model and serial number of the appliance. This data is provided on the data label adhered to the base of the appliance and on the duplicate data label in the operating pack.



IMPORTANT NOTE

It is the law in New Zealand that this appliance must be installed by authorised persons. The installation must comply with all the appropriate New Zealand Standards and Regulatory Requirements, with particular reference to the New Zealand Electrical Standards.

Any attempt to install this or any other Parmco product without an authorised person could result in damage to the product and possible health hazard. Not having an authorised person install this appliance may result in all associated warranties from Parmco Appliances being null and void.

INSTALLATION

- Installation of this appliance and its connection to the electrical mains must only be carried out by authorised personnel. Before any service procedure, it is important to ensure that the appliance is DISCONNECTED from the electrical mains.
- DO NOT MODIFY THIS APPLIANCE.
- After removing the appliance from the packaging, make sure that it is undamaged. Otherwise, contact your dealer before operating this appliance.
- Make sure that this appliance is installed in accordance with the ventilation requirements.

NOTES TO THE AUTHORISED INSTALLER



This appliance shall only be installed by an authorised person. This appliance shall only be installed in complete accordance with the Electrical Standards of New Zealand. All local regulations, building code requirements and all other statutory requirements must be met.

Data Label

The data label is located at the rear of the appliance. A duplicate data label is supplied to adhere to a suitable accessible area next to the appliance. The data label on the appliance must NEVER be removed.

Before any procedure, it is important to check that the appliance is DISCONNECTED from the electrical mains. Parmco declines all responsibility for any damage deriving from installations that are in breach of the regulations in force or from failure to comply with these installation instructions.

ELECTRICAL CONNECTION

The appliance comes fitted with an approved 15 amp cord which may be connected to a correctly earthed socket outlet. It is necessary that all installation and connections are carried out by qualified personnel and that the connections meet all New Zealand Regulatory Requirements.

Before connecting to the mains make sure that:

- The electrical counter, the safety valve, feed cable and socket are suitable to withstand the maximum load requirements as detailed on the rating label.
- The supply system is regularly grounded as per New Zealand Regulations
- The socket or omnipolar switch can easily be reached after the appliance is installed.
- After connection of the appliance to the mains, ensure the cord does not come into contact with any parts of this appliance subject to heating.
- Never use reductions, shunts, adaptors which can cause overheating or burning.

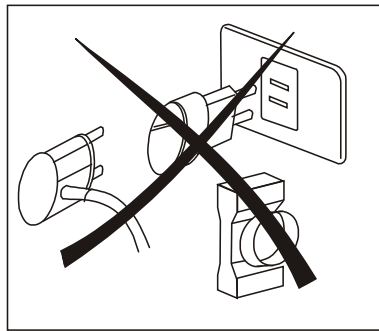

When handling this oven it is essential that you always use the purpose provided handles recessed into the sides of the oven. This will ensure that the oven carcass and door is not stressed by lifting. DO NOT use the door handle when lifting this appliance into position. This could result in damage to the hinges.

INSTALLATION INTO CABINETS



In order for this oven to perform correctly, it requires correct ventilation. Special care must be paid to the ventilations requirements of this oven. The oven must be installed as per the installation instructions below.

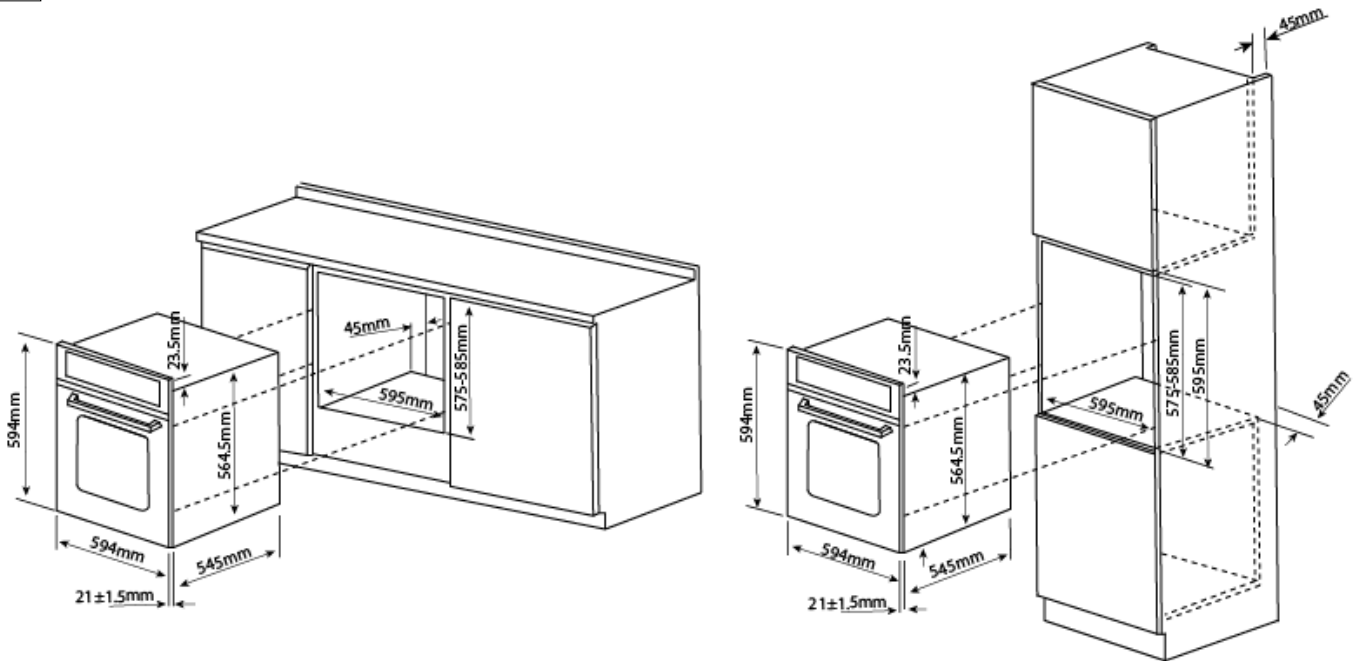

NOTE: Dimensions provided above for the cut-out are for a face mount only!

In order to ensure adequate ventilation, the back panel of the cabinet unit must be removed. Installing the oven so that it rests on two strips of wood is preferred. If the oven will rest on a continuous panel there must be an aperture of at least 560mm wide by 45mm deep from the rear of the cabinet.

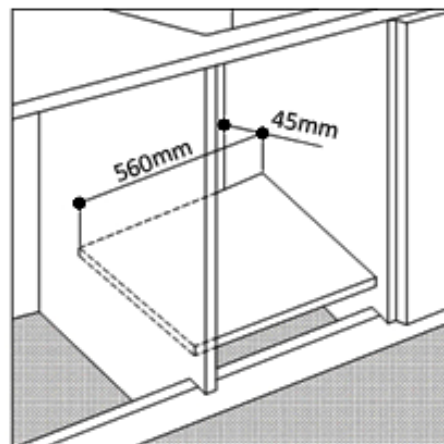
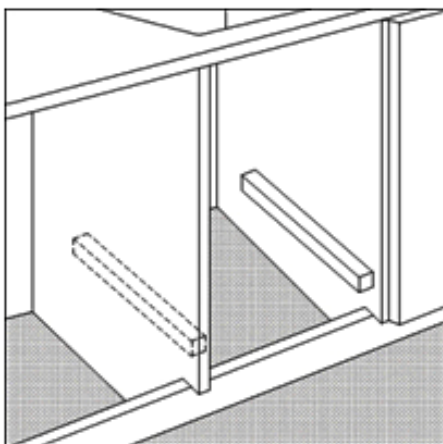

The panels that are immediately adjacent to the oven must be of a material that has heat resistant qualities. In particular, cabinets with veneer finishes must be assembled with glues that can withstand temperatures of up to 100°C. Special attention must be paid to the edge banding finish on the cabinetry. Special care must be taken with vacuum applied veneers commonly referred to as “thermowrap”. If in doubt, always refer to the technical data supplied by the kitchen cabinetry manufacturer.



p: 09 573 5678
f: 09 573 5699
e: sales@parmco.co.nz
w: www.parmco.co.nz



Parmco Appliances extended 5 year warranty



The Warranty:

- Subject to the terms and conditions contained within this warranty, if the product is not of Acceptable Quality (as defined in the Consumer Guarantees Act) within 5 years of the date of original purchase, then Parmco Sales undertakes to repair or, at it's sole discretion, replace the product.
- The warranty does not cover the costs of transport, mileage or travelling time if the product is located beyond 30km of a recognised Service Agent.
- This warranty is offered as an extra benefit, and does not affect other legal rights, which can not be modified or excluded by agreement.
- This warranty only applies to goods supplied and installed in the North and South Islands of New Zealand.
- The provisions of this warranty are in addition to the rights and remedies available to consumers under the Consumer Guarantees Act 1993.

The Warranty is not valid:

- If the product is not installed and operated in accordance with the operating instructions.
- If the product is not installed to comply with the electrical, gas, plumbing and other Regulations and Codes of Practice in New Zealand.
- If the product is operated on voltages or frequencies outside the normal range for domestic appliances in New Zealand.
- If the product is not used in normal domestic use, or if it is used in a business as defined in the Consumer Guarantees Act.
- If any serial number has been removed or defaced.
- If proof of date of purchase is not supplied, except at the sole discretion of Parmco Sales. Proof of purchase can be for the product itself, or if installed with a kitchen or house then proof of purchase can be from a Parmco reseller of products supplied by Parmco.

Liability under this warranty will not be accepted for:

- Wear and tear from normal domestic use.
- Damage in transport.
- Damage caused to the product by neglect, abuse, negligence, wilful act or misuse.
- Any defect caused by accident, misuse, neglect, tampering with or unauthorised modifications of the appliance or any attempt at internal adjustment or repair by any person other than an Authorised Service Agent.
- Service calls that relate principally to the following:
 - Instruction on how to use the product.
 - Repair or replacement of house fuses, electrical wiring, gas fitting or plumbing.
- Wear and tear caused by normal use of the product.
- Normal or scheduled maintenance including blocked filters or ducting.
- Consumable items such as light bulbs.
- Any damage to ceramic glass hobs caused by spills when cooking.
- Any breakage or damage of glass items.
- Any damage caused by non recommended product used for cleaning, maintaining, lubricating or similar.
- Any aspect relating to the installation of the product, or damage caused during installation.
- Any third party (including reseller) or consequential loss or damage (direct or indirect) however arising.

Product _____ Date of purchase _____

Dealer / Retailers Name _____

Please retain this Warranty card together with receipt or other proof of purchase date when seeking service during the warranty period

Please contact Parmco at 09 573 5678 if your appliance needs servicing under warranty. Please have your model number and proof of purchase ready. Warranty repairs must be authorized by Parmco.