

PARMCO

Installation and Operating Instructions

Model:

RR6S440

RR9S440

As part of Parmco Appliances commitment to improving and updating product ranges, we reserve the right to alter, change and update technical specifications and appearance attributes of all Parmco Appliances products. E&OE

V20251129

PARMCO

p: 09 573 5678
f: 09 573 5699
e: sales@parmco.co.nz
w: www.parmco.co.nz

Inspiring kitchens, entertaining homes

Parmco Appliances extended 7 year warranty



The Warranty:

- This appliance is intended for domestic use in the owners' home. Use of the appliance for commercial purposes will limit the warranty period (please see Parmco website for commercial details).
- Subject to the terms and conditions contained within this warranty, if the product is not of Acceptable Quality (as defined in the Consumer Guarantees Act) within 7 years of the date of original purchase, then Parmco Sales undertakes to repair or, at its sole discretion, replace the product.
- The warranty does not cover the costs of transport, mileage or travelling time if the product is located beyond 30km of a recognised Service Agent.
- This warranty is offered as an extra benefit, and does not affect other legal rights, which can not be modified or excluded by agreement.
- This warranty only applies to goods supplied and installed in the North and South Islands of New Zealand.
- The provisions of this warranty are in addition to the rights and remedies available to consumers under the Consumer Guarantees Act 1993.

Product _____ Date of purchase _____
Serial Number _____
Dealer / Retailers Name _____

Please retain this Warranty card together with receipt or other proof of purchase date when seeking service during the warranty period

Please contact Parmco at 09 573 5678 if your appliance needs servicing under warranty. Please have your model number and proof of purchase ready. Warranty repairs must be authorized by Parmco.

The Warranty is not valid:

- If the product is not installed and operated in accordance with the operating instructions.
- If the product is not installed to comply with the electrical, gas, plumbing and other Regulations and Codes of Practice in New Zealand.
- If the product is operated on voltages or frequencies outside the normal range for domestic appliances in New Zealand.
- If the product is not used in normal domestic use, or if it is used in a business as defined in the Consumer Guarantees Act.
- If any serial number has been removed or defaced.
- If proof of date of purchase is not supplied, except at the sole discretion of Parmco Sales. Proof of purchase can be for the product itself, or if installed with a kitchen or house then proof of purchase can be from a Parmco reseller of products supplied by Parmco.
- If the products are purchased in a second hand condition from other parties (including but not limited to TradeMe, Sella, etc.)

Liability under this warranty will not be accepted for:

- Wear and tear caused by normal domestic use of the product.
- Damage in transport.
- Damage caused to the product by neglect, abuse, negligence, wilful act or misuse.
- Any costs associated with the repair, replacement, removal or reinstallation of products installed in a damaged condition.
- Any defect caused by accident, misuse, neglect, tampering with or unauthorised modifications of the appliance or any attempt at internal adjustment or repair by any person other than an Authorised Service Agent.
- Service calls that relate principally to the following:
 - Instruction on how to use the product.
 - Repair or replacement of house fuses, electrical wiring, gas fitting or plumbing.
 - Normal or scheduled maintenance including blocked filters or ducting.
 - Consumable items such as light bulbs.
- Any damage to hobs caused by spills when cooking.
- Any breakage or damage of glass items.
- Any damage caused by non recommended product used for cleaning, maintaining, lubricating or similar.
- Any aspect relating to the installation of the product, or damage caused during installation including blocked access for repair.
- Any third party (including reseller) or consequential loss or damage (direct or indirect) however arising.

Subject to updates without prior notice, please visit www.parmco.co.nz for the latest version.

E & O.E. 727626062017



Dear Valued Customer,

Thank you and congratulations on purchasing your new Parmco appliance.

All Parmco products are made to the highest quality and design standards. We are sure you will enjoy your new appliance.

As a note, please read through these instructions carefully. These will assist you in gaining a complete understanding of the functions and features offered by your appliance. Please take special note of all detailed technical information and installation instructions. It is essential that you follow these instructions to ensure the safety and reliability of this appliance.

Furthermore, not using appropriate personnel to install this appliance may affect any future warranty claims lodged, so please check with Parmco Appliances before any installation is carried out.

We hope you enjoy your new appliance. If you would like to find out more about this product or any other products in Parmco's extensive range, visit us online at www.parmco.co.nz.

Regards,
The Parmco Team

P A R M C O

Inspiring kitchens, entertaining homes

Index

Content	Page
Important Safety Information	1
Installation	3
Use and care	5

Important safety information

For best performance and to extend the life of your appliance we recommend that you read the instructions in this owner's manual thoroughly before using your new appliance. It will provide you with all the information you need to ensure its safe installation, proper use and maintenance. Retain this owner's manual for future reference.



To maintain the efficiency and safety of this appliance we recommend the following:

BEFORE USING THIS APPLIANCE

Read the instructions thoroughly

- Remove all plastic protective films on the appliance before operating the appliance.
- The brackets and screws to fix this canopy to the wall are provided and are fixed to the inside packaging. Please check that the brackets and screws are not discarded with the packaging.

SAFETY PRECAUTION

- Take caution when the rangehood is operating at the same time as an open fireplace or burner that is dependent on air and is supplied by something other than electrical energy, as the rangehood removes the air from the environment which is needed by the fireplace or burner for combustion.
- Appliance should only be used with rated voltage and frequency.
- A fire risk exists if cleaning is not carried out in accordance with the instructions in this manual.

WARNING

- This appliance can only be used safely when it is correctly connected to an efficient earthing system in compliance with New Zealand Electrical Standards requirements.
- Do not check the status of the filters when the rangehood is operating.

- The exposed parts of this appliance heat up during the cooking process and remain hot for some time afterwards, even after it has been switched off. Keep children well away during operation and while the unit is cooling down.
- Do not disconnect the appliance with wet hands.
- Do not use flame cooking underneath the rangehood.
- Avoid free flame, as it damages the filters and is a fire hazard.
- When frying, never leave the pan alone because the cooking oil could flare up.
- Keep the appliance thoroughly cleaned. Residues may cause fire risks.
- Before maintenance or cleaning, always ensure that the appliance is disconnected from the mains.
- DO NOT use a steam cleaner to clean this appliance.
- Avoid improper or dangerous use of this appliance.
- Do not obstruct the ventilation or heat dissipation slots.
- This appliance must only be used by adults. Make sure that children do not touch the controls or play with the appliance. Young children should be supervised to ensure they do not play with the appliance.
- This appliance is not intended for use by persons (including children) with reduced physical, sensory, or mental capabilities, or lack of experience and knowledge, unless they have been given supervision or instruction concerning the use of this appliance by a person responsible for their safety.
- Packaging items such as plastic bags, polystyrene, nails etc that this appliance is delivered in are potentially dangerous, and therefore appropriate measures must be taken to prevent children from coming into contact with them.
- If the supply cord is damaged, it must be replaced by the manufacturer or a qualified service agent.
- This appliance is intended for indoor use only. Avoid exposing the appliance to atmospheric elements such as direct sunlight and rain.
- This appliance is designed for non-commercial, household use only and must not be altered in any way.
- Do not dispose of electrical appliances as unsorted waste – use separate collection facilities. Contact your local City Council for more information.
- If electrical appliances are disposed of in landfills or dumps, hazardous substances can leak into the groundwater and into food supplies.

Installation

The appliance can be used as a rangehood or can be mounted beneath a wall cupboard and is suitable for use as an exhaust hood or as a recirculating hood. If an exhaust facility (an exhaust duct or a ventilating shaft) is available, then we recommend the hood be installed as an exhaust hood as most of the smells and vapours that arise when cooking or frying can be almost completely removed from the kitchen.

There are 2 options in installing your rangehood.

Option 1: Fastening the rangehood on the wall:

- Step 1: The rangehood should be placed at a minimum distance of 65cm above the cooking surface when placed above an electric hob and a minimum of 75cm above the cooking surface when placed above a gas cooktop.
- Step 2: To install, drill 4 holes of 8mm along a level line at the desired height.
- Step 3: Insert the nuts into the holes.
- Step 4: Insert the screws into the nuts and tighten, ensuring that they are fixed into material that has sufficient load capacity to hold the weight of the rangehood.
- Step 5: Put the rangehood onto the fixed screws.
- Step 6: Fix the rangehood onto the wall, like demonstrated in the above picture.
- Step 7: Put the one way valve onto the rangehood.

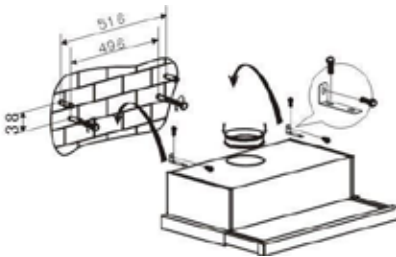
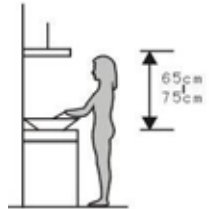

RR6S440

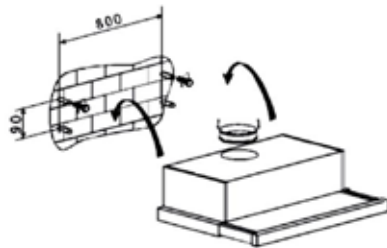

RR9S440

Option 2: Mounting the rangehood under a wall cupboard (ensure that the cupboard can support the weight of the rangehood):

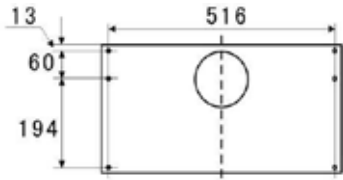

RR6S440

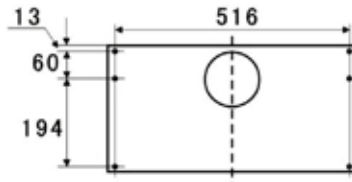

RR9S440

- Step 1: The rangehood should be placed at a minimum distance of 65cm above the cooking surface when placed above an electric hob and a minimum of 75cm above the cooking surface when placed above a gas cooktop.
- Step 2: Referring to the diagram above, drill 6 holes of 4mm at the bottom of the wall cupboard.
- Step 3: Put the one way valve onto the rangehood, then install the rangehood on the bottom of the cupboard, tightening with the 6 enclosed screws.
- Step 4: Install the adjusted board on the bottom of the hood in order to keep out the gap between hood back and cupboard.

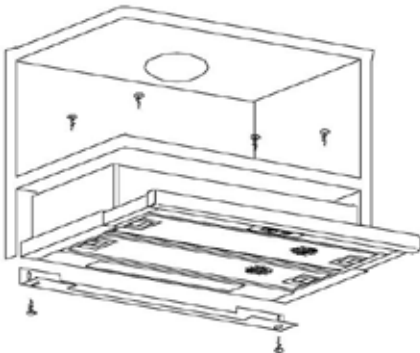

Installation of kitchen ventilation over electrical and gas cooktops must be undertaken in full accordance and reference to the relevant NZ building standards.

Use and Care

OPERATION

For best result, turn the rangehood on 15 minutes prior to your cooking. Once done cooking, leave the rangehood in operation for 15 minutes to completely remove cooking vapours and odours.

Slide Control

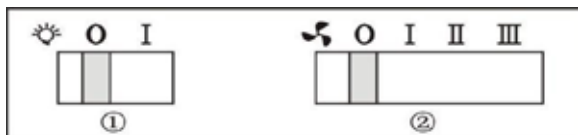

① Represents the light. Push the switch to "I" to turn the light on, and "O" to turn the light off.

② Represents the motor speed. "I", "II", and "III" refers to "low", "medium", "high" respectively. Push the switch to "O" to turn the motor off.

Rocker switch

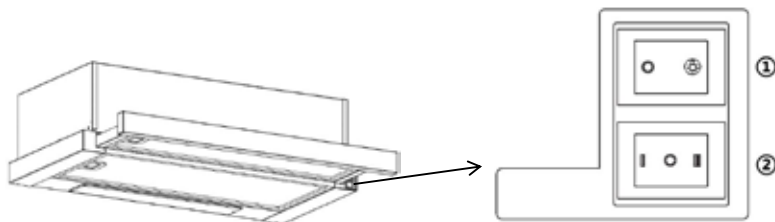

① Represents the light. Push the switch to "⊗" to turn the light on, and "O" to turn the light off.

② Represents the motor speed. "I", "II" refers to "low", "high" respectively. Push the switch to "O" to turn the motor off.

USE AND MAINTENANCE

- Please turn off the appliance if it is not in use.
- Do not have flame under the rangehood.
- Discontinue use if the appliance is damaged, especially with regards to the supply cord and the case.
- If the supply cord is damaged, it must be replaced by the manufacturer or a qualified service agent.
- Do not immerse the appliance in liquid.
- The exhaust air must not be discharged into a flue that is used for exhausting fumes from an appliance using gas or other fuels.

In order to prevent fire hazard, it is recommendable to clean the filter every 2 months by carrying out the following instructions.

- Unplug the appliance from the power supply before cleaning, then remove the filters from the rangehood and wash them in a solution of water and neutral liquid detergent, leaving to soak.
- Rinse thoroughly with warm water and leave to dry.
- The filters can be washed in the dishwasher, however, different detergents have different caustic content and the aluminium filters may alter in colour.
- It can be washed at more or less frequent intervals depending on how often the hood is used.
- Clean the surfaces of the cooker hood regularly using a cloth moistened with denatured alcohol or non-abrasive liquid detergent.
- Keep the motor and other spare parts free from water, as this will cause damage to the appliance.
- Replace filters approximately every 4 months.
- There is a fire risk if cleaning is not carried out in accordance with the instructions.

DISPOSAL

Parmco has a commitment to being environmentally responsible. To avoid potential negative impacts on the environment please ensure that this appliance is disposed of correctly. This product must not be treated as household waste. Instead, it should be handed over to an appropriate collection point for recycling of electrical, electronic and steel components. Disposal should always be carried out in an environmentally appropriate manner.



For more detailed information about treatment, recovery and recycling of this product, please contact your local City Council office.

SERVICE AND PARTS

Before leaving the factory, this appliance was tested and adjusted by specialist skilled staff to give the best operating results. Any subsequent necessary repairs or adjustments must be carried out with the greatest of care and attention by an authorized personnel. For this reason, we strongly advise you to contact Parmco Service Department, specifying the nature of the problem, the model and serial number of the appliance. This data is provided on the data label adhered to the base of the appliance and on the duplicate data label in the operating pack.

WARRANTY

Your new appliance is covered by a warranty. The details of your warranty are in the back of this manual. Keep the purchase receipt that documents your purchase of the appliance and your purchase date, as you will need to provide these as proof of purchase for warranty repairs. Warranty cannot be claimed without proof of purchase.