

Our latest addition. Inspiring designs for New Zealand Kitchens.

900MM STYLELINE CANOPY STAINLESS STEEL, LED RCAN-9S-500L

- 3 Speed Settings
- Air Movement Capacity: 500m³/hour
- Full width removable filters
- Aluminium Filters
- Integrated LED Lights
- Durable Stainless Steel Construction
- Push Controls
- Extendable Chimney Cover
- Ducting 150mm
- Noise: 48db
- 7 year Warranty

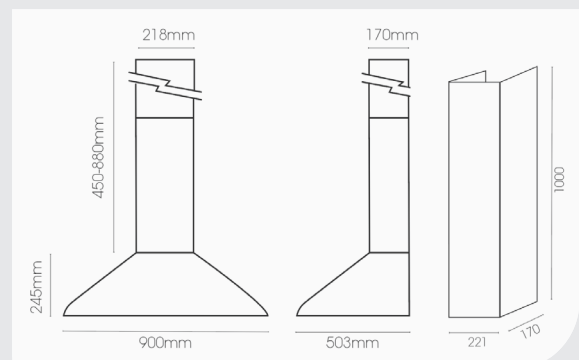

Impressive 7 Year Warranty

Note: 7 year warranty is for domestic use only.
For more information visit www.parmco.co.nz

AVAILABLE NOW

Ask your local Parmco representative for pricing.

PARMCO

Inspiring kitchens, entertaining homes