

Our latest addition. Inspiring designs for New Zealand kitchens.

251L CHEST FREEZER WHITE CHF-251

- 251L White Freezer
- 2 Star Energy Rating
- Mechanical Temperature Control
- Waste Disposal Device
- Direct Cooling
- Wire Basket
- Rollers & Adjustable Legs
- 950mm x 617mm x 850mm

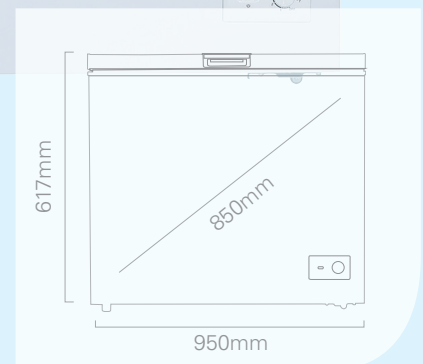

Impressive 7 Year Warranty

Note: 7 year warranty is for domestic use only.
For more information visit www.parmco.co.nz

Ask your local Parmco
representative for pricing.

PARMCO

Inspiring kitchens, entertaining homes